

**CPU 221**

**24 V DC/ 24 V DC/ 24 V DC**

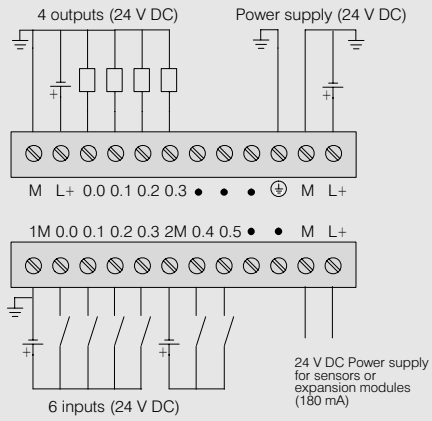

6ES7 211-0AA20-0XB0

**100 to 230 V AC/24 V DC/relay**

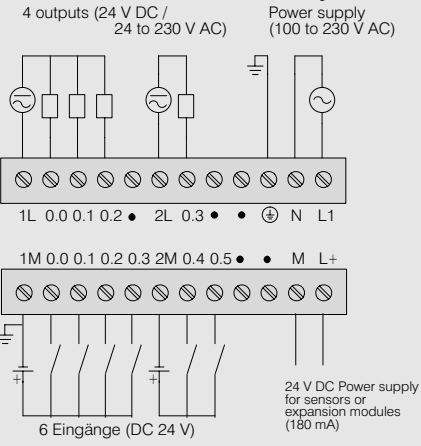

6ES7 211-0BA20-0XB0

## CPU 212

### 24 V DC/24 V DC/24 V DC

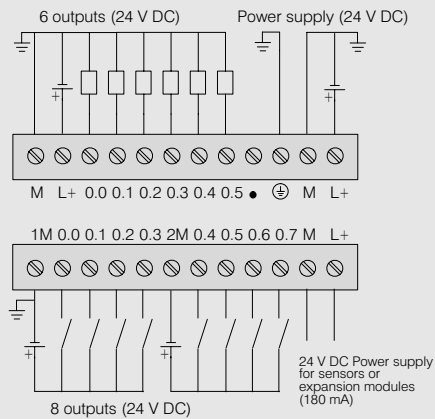

6ES7 212-1AA01-0XB0

### 230 V AC/24 V DC (sink input)/relay

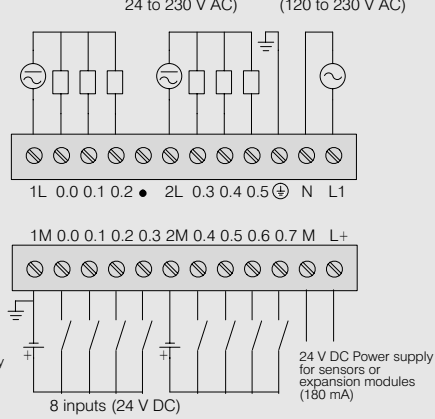

6ES7 212-1BA01-0XB0

### 24 V AC/24 V DC (sink input)/relay

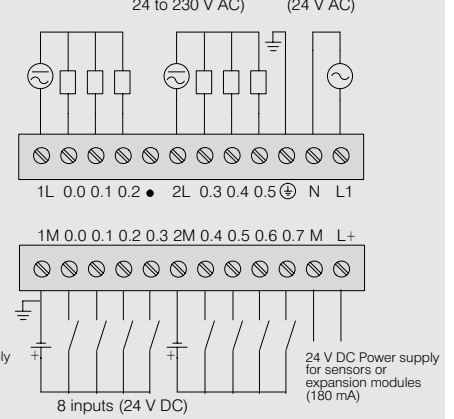

6ES7 212-1FA01-0XB0

### 230 V AC/24 V DC (source input)/relay 230 V AC/120 V AC/230 V AC

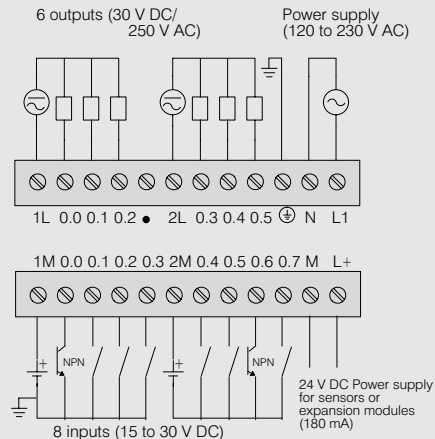

6ES7 212-1BA10-0XB0

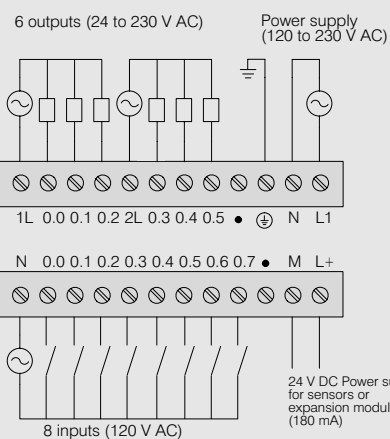

6ES7 212-1CA01-0XB0

### 230 V AC/24 V AC/230 V AC

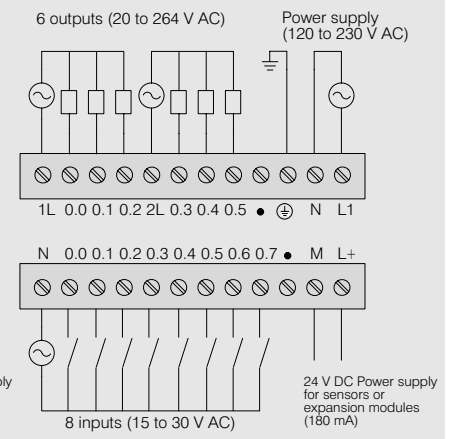

6ES7 212-1DA01-0XB0

### 230 V AC/120 V AC/relay

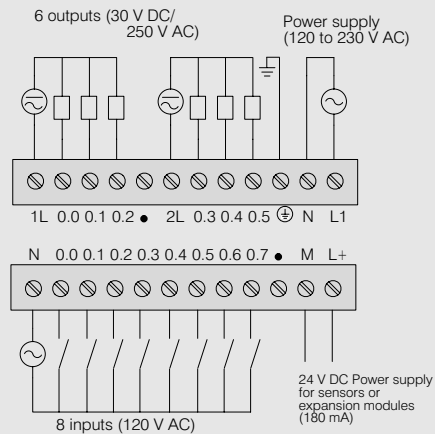

6ES7 212-1GA01-0XB0

# SIMATIC S7-200 CPUs

## CPU 222

### 24 V DC/24 V DC/24 V DC

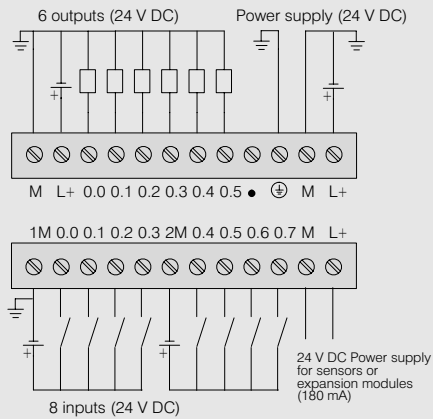

6ES7 212-1AB20-0XB0

### 100 to 230 V AC/24 V DC/relay

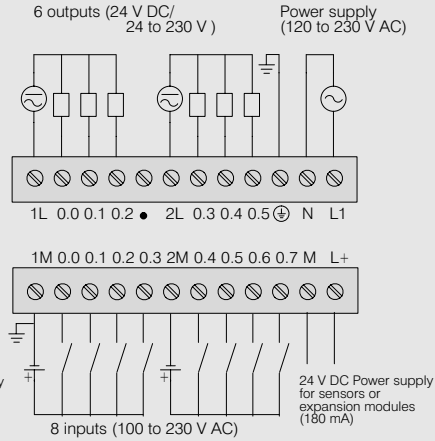

6ES7 212-1BB20-0XB0

## CPU 214

### DC

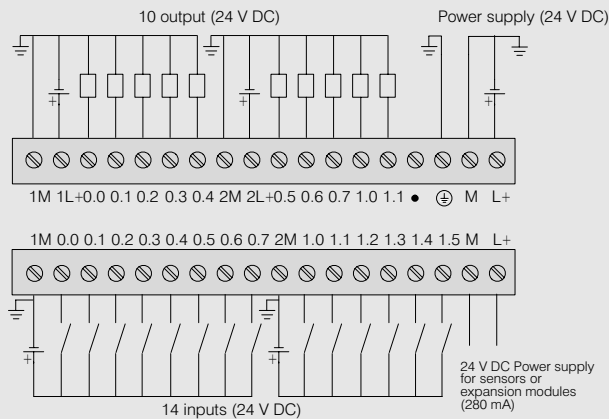

6ES7 214-1AC01-0XB0

### Relays (sink input)

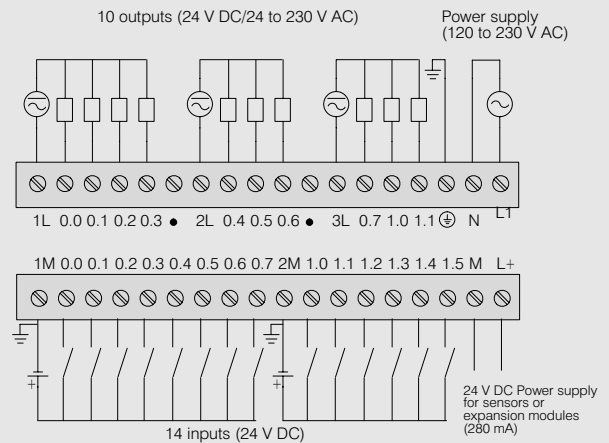

6ES7 214-1BC01-0XB0

### Relays (source input)

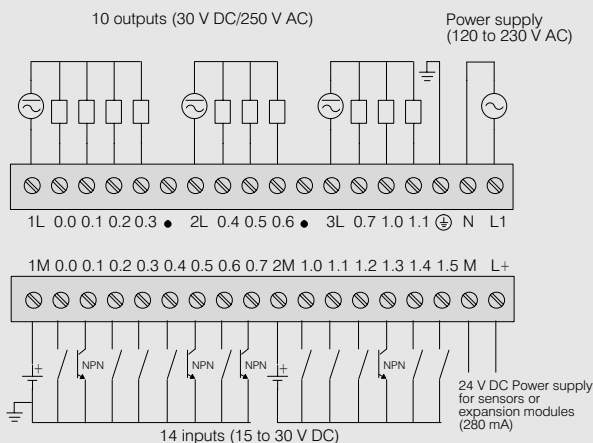

6ES7 214-1BC10-0XB0

### AC (24 V AC inputs)

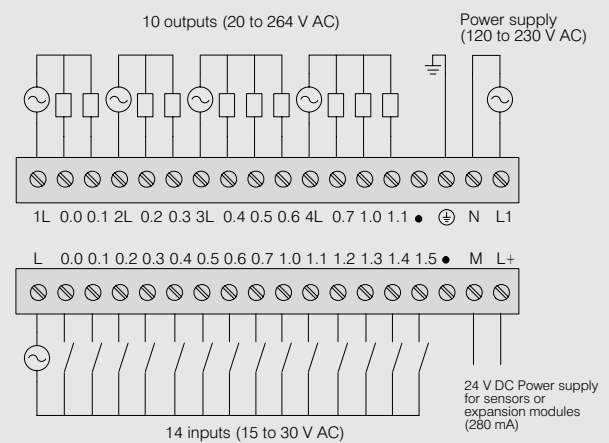

6ES7 214-1DC01-0XB0

## CPU 214(cont.)

### AC (120 V AC inputs)

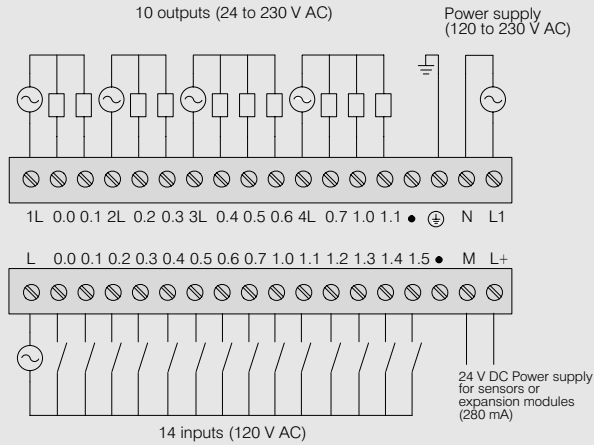

6ES7 214-1CC01-0XB0

### AC (120 V AC inputs, relays (sink input))

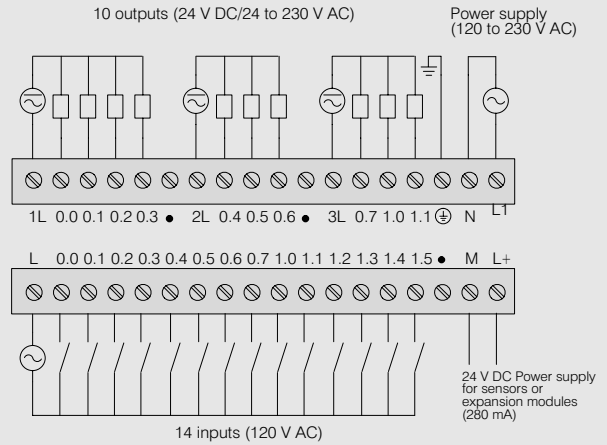

6ES7 214-1GC01-0XB0

## CPU 224

### DC

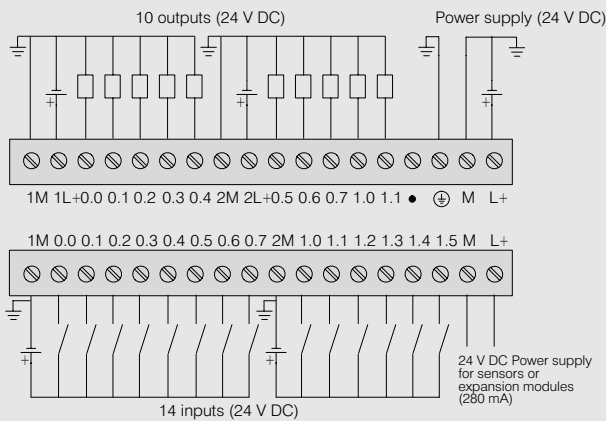

6ES7 214-1AD20-0XB0

### 100 to 230 V AC/24 V DC/ relays

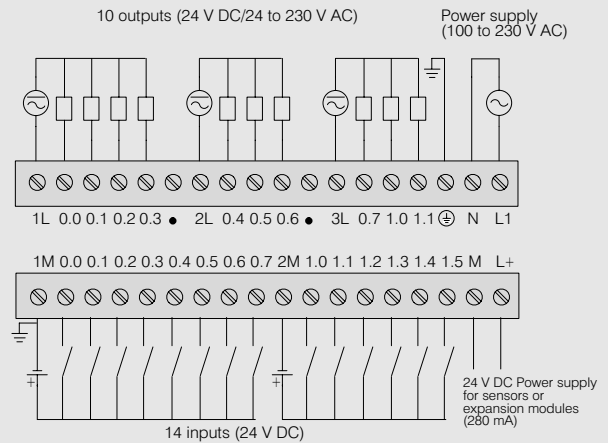

6ES7 214-1BD20-0XB0

## CPU 215

### DC

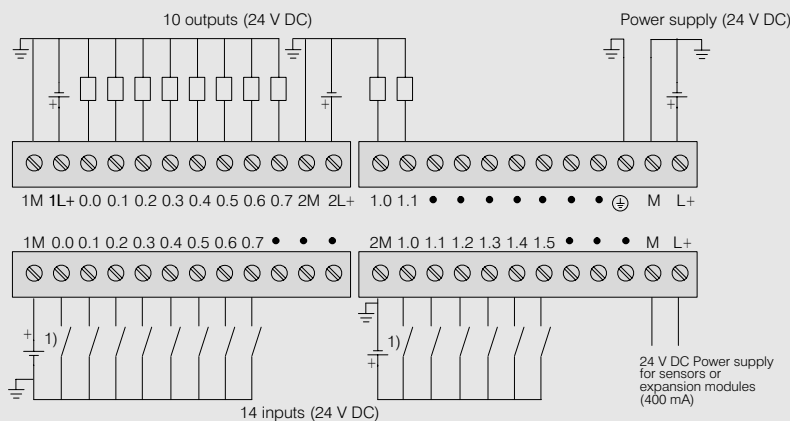

6ES7 215-2AD00-0XB0

1) The inputs can be operated as sink inputs or as source inputs per group

# SIMATIC S7-200 CPUs

## CPU 215 (cont.)

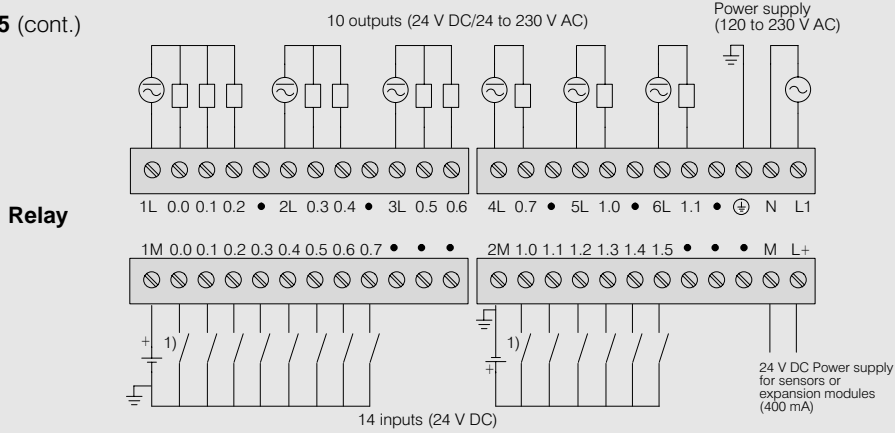

6ES7 215-2BD00-0XB0

1) The inputs can be operated as sink inputs or as source inputs per group

## CPU 216

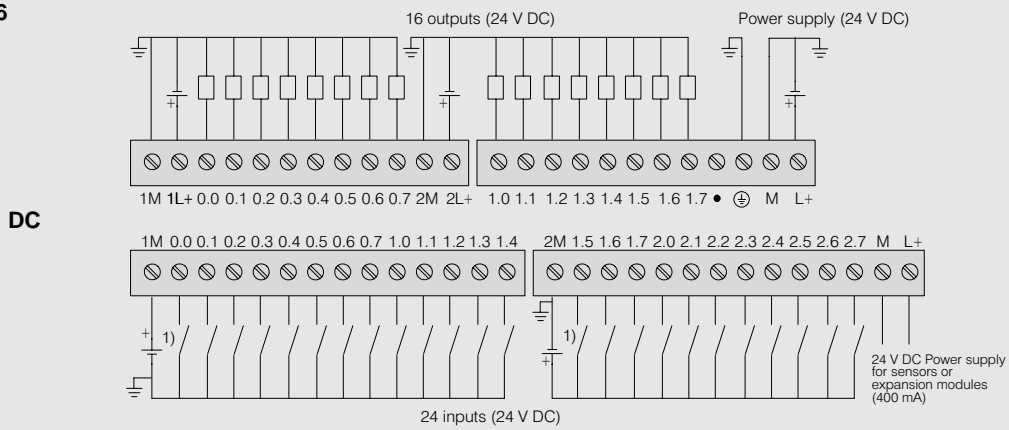

6ES7 216-2AD00-0XB0

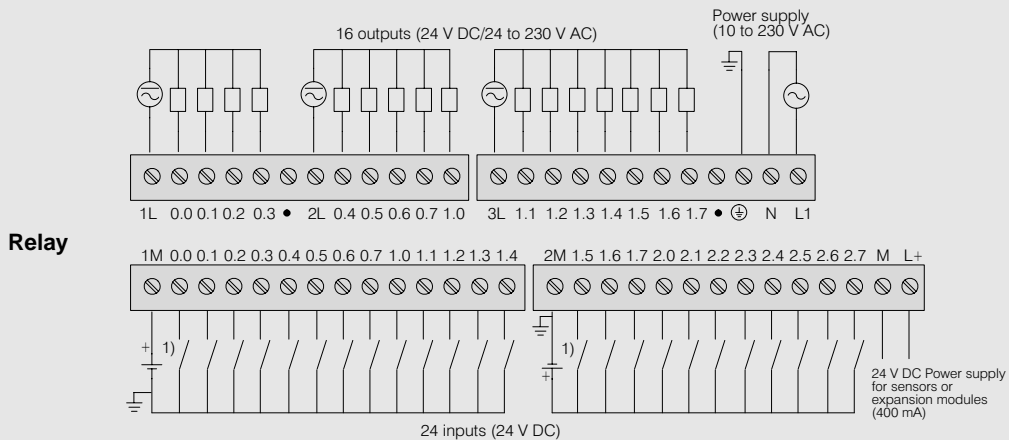

6ES7 216-2BD00-0XB0

1) The inputs can be operated as sink inputs or as source inputs per group

### CPU 212

Item	Accessories (see below)	System configuration			Modules		Price	
		0	1	2	No.	Current consumption from backplane bus mA	Current consumption from 24 V DC mA	Unit
CPU 212, 24 V DC supply, 24 V DC inputs, 24 V DC outputs	Order No. 6ES7 212-1AA01-0XB0	1,2,3				60 <sup>1)</sup>		
CPU 212, 120-230 V AC supply, 24 V DC inputs (sink input), relay outputs	Order No. 6ES7 212-1BA01-0XB0	1,2,3				60 <sup>1)</sup>		
CPU 212, 120-230 V AC supply, 24 V DC inputs (source input), relay outputs	Order No. 6ES7 212-1BA10-0XB0	1,2,3				60		
CPU 212, 120-230 V AC supply, 24 V AC inputs, 120-230 V AC outputs	Order No. 6ES7 212-1DA01-0XB0	2,3				—		
CPU 212, 120-230 V AC supply, 120 V AC inputs, 120-230 V AC outputs	Order No. 6ES7 212-1CA01-0XB0	2,3				—		
CPU 212, 120-230 V AC supply, 120 V AC inputs, relay outputs	Order No. 6ES7 212-1GA01-0XB0	2,3				—		
CPU 212, 24 V AC supply, 24 V DC inputs (sink input), relay outputs	Order No. 6ES7 212-1FA01-0XB0	2,3				—		
EM 221 digital input modules: 8 x 24 V DC, sink input	Order No. 6ES7 221-1BF00-0XA0	2,4				60		
EM 221 digital input modules: 8 x 24 V DC, source output	Order No. 6ES7 221-1BF10-0XA0	2,4				60		
EM 221 digital input modules: 8 x 24 V AC	Order No. 6ES7 221-1JF00-0XA0	2,4				70		
EM 221 digital input modules: 8 x 120 V AC	Order No. 6ES7 221-1EF00-0XA0	2,4				70		
EM 222 digital output modules: 8 x 24 V DC	Order No. 6ES7 222-1BF00-0XA0	2,4				80		
EM 222 digital output modules: 8 x relay	Order No. 6ES7 222-1HF00-0XA0	2,4				80		
EM 222 digital output modules: 8 x 24 to 230 V AC	Order No. 6ES7 222-1EF00-0XA0	2,4				120		
EM 223 digital I/O modules: 4 inputs at 24 V DC, 4 outputs at 24 V DC	Order No. 6ES7 223-1BF00-0XA0	2,4				80		
EM 223 digital I/O modules: 8 inputs at 24 V DC, 8 outputs at 24 V DC <sup>3)</sup>	Order No. 6ES7 223-1BH00-0XA0	2,4				120		
EM 223 digital I/O modules: 16 inputs at 24 V DC, 16 outputs at 24 V DC	Order No. 6ES7 223-1BL00-0XA0	2,3,4				210		
EM 223 digital I/O modules: 4 inputs at 24 V DC, 4 relay outputs	Order No. 6ES7 223-1HF00-0XA0	2,4				80		
EM 223 digital I/O modules: 8 inputs at 24 V DC, 8 relay outputs	Order No. 6ES7 223-1PH00-0XA0	2,4				100		
EM 223 digital I/O modules: 16 inputs at 24 V DC, 16 relay outputs <sup>4)</sup>	Order No. 6ES7 223-1PL00-0XA0	2,3,4				160		
EM 231 analog input module: 3 inputs, 12 bits + sign	Order No. 6ES7 231-0HC00-0XA0	2,4				100		
EM 232 analog output module: 3 inputs, 12 bits + sign	Order No. 6ES7 232-0HB00-0XA0	2,4				70		
EM 235 analog I/O module: 3 inputs, 1 output, 12 bits	Order No. 6ES7 235-0KD00-0XA0	2,4				70		
CP 242-2 communications processor <sup>3)</sup>	Order No. 6GK7 242-2AX00-0XA0					200		
CP 242-8 communications processor <sup>3)/4)</sup>	Order No. 6GK7 242-8DP00-0XA0					340		

- 1) Total input current of all inputs  
 2) Power supply for relay coils  
 3) Only 1 module can be used  
 4) Cannot be used with 6ES7 212-1DA01-0XA0/6ES7 212-1CA01-0XA0

Max. 180 mA; an additional 24 V DC power supply is required if this figure is exceeded

Item	Order No.	No.	Price Unit	Total	Item	Order No.	No.	Price Unit	Total
1	SIM 274 simulator for CPU 212				3	Terminal block, 12-pin, 10 pieces	6ES7 290-2AA00-0XA0		
2	Ground terminals (10 pieces)				4	Terminal block, 14-pin, 10 pieces	6ES7 290-2CA00-0XA0		
	Labeling strips, 24 pieces								
				<b>Total</b>					<b>Total</b>

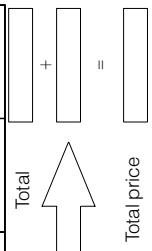



### CPU 214

Item	Accessories (see below)	System configuration							Modules		Price			
		Order No.	1	2	3	4	5	6	7	No.	Current consumption from backplane bus mA	Current consumption from 24 V DC mA	Unit	Total
CPU 214, 24 V DC supply, 24 V DC inputs, 24 V DC outputs		6ES7 214-1AC01-0XB0	1, 2, 3, 4							-660	105 <sup>1)</sup>			
CPU 214, 120-230 V AC supply, 24 V DC inputs (sink input), relay outputs		6ES7 214-1BC01-0XB0	1, 2, 3, 4							-660	105 <sup>1)</sup>			
CPU 214, 120-230 V AC supply, 24 V DC inputs (source input), relay outputs		6ES7 214-1BC10-0XB0	1, 2, 3, 4							-660	105			
CPU 214, 120-230 V AC supply, 24 V AC inputs, 120-230 V AC outputs		6ES7 214-1DC01-0XB0	1, 2, 4							-560	—			
CPU 214, 120-230 V AC supply, 120 V AC inputs, 120-230 V AC outputs		6ES7 214-1CC01-0XB0	1, 2, 4							-560	—			
CPU 214, 120-230 V AC supply, 120 V AC inputs, relay outputs		6ES7 214-1GC01-0XB0	1, 2, 4							-560	—			
EM 221 digital input modules: 8 x 24 V DC, sink input		6ES7 221-1BF00-0XA0	3,5							60	60 <sup>1)</sup>			
8 x 24 V DC, source input		6ES7 221-1BF10-0XA0	3,5							60	60			
8 x 24 V AC		6ES7 221-1JF00-0XA0	3,5							70	—			
8 x 120 V AC		6ES7 221-1EF00-0XA0	3,5							70	—			
EM 222 digital output modules: 8 x 24 V DC		6ES7 222-1BF00-0XA0	3,5							80	—			
8 x relay		6ES7 222-1HF00-0XA0	3,5							80	85 <sup>2)</sup>			
8 x 24 to 230 V AC		6ES7 222-1EF00-0XA0	3,5							120	—			
EM 223 digital I/O modules: 4 inputs at 24 V DC, 4 outputs at 24 V DC		6ES7 223-1BF00-0XA0	3,5							80	30			
8 outputs at 24 V DC, 8 outputs at 24 V DC		6ES7 223-1BH00-0XA0	3,5							120	60			
16 inputs at 24 V DC, 16 outputs at 24 V DC		6ES7 223-1BL00-0XA0	3,5,6							210	120			
4 inputs at 24 V DC, 4 relay outputs		6ES7 223-1HF00-0XA0	3,5							80	65			
8 inputs at 24 V DC, 8 relay outputs		6ES7 223-1PH00-0XA0	3,5							100	125			
16 inputs at 24 V DC, 16 relay outputs		6ES7 223-1PL00-0XA0	3,5,6							160	250			
4 inputs at 120 V AC, 4 outputs at 120-230 V AC		6ES7 223-1EF00-0XA0	3,5							100	30			
EM 231 analog input module: 3 inputs, 12 bits + sign		6ES7 231-0HC00-0XA0	3,5							70	60			
EM 232 analog output module: 3 inputs, 12 bits + sign		6ES7 232-0HB00-0XA0	3,5							70	60			
EM 235 analog I/O module: 3 inputs, 1 output, 12 bits		6ES7 235-0KD00-0XA0	3,5							70	80			
CP 242-2 communications processor		6GK7 242-2AX00-0XA0								200	—			
CP 242-8 communications processor		6GK7 242-8DP00-0XA0								340	60			

1) Total input current of all inputs

2) Power supply for relay coils

Max. 280 mA; an additional 24 V DC power supply is required if this figure is exceeded

Accessories	Item	Order No.	No.	Price Unit	Total	Item	Order No.	No.	Price Unit	Total
1	MC 291 memory submodule					3	Labeling strips, 24 pieces	6ES7 292-2AA00-0XA0		
	EEPROM 8 Kbytes	6ES7 291-8GC00-0XA0				4	Terminal block, 18-pin, 10 pieces	6ES7 290-2BA00-0XA0		
2	SIM 274 simulator for CPU 214	6ES7 274-1XH00-0XA0				5	Terminal block, 14-pin, 10 pieces	6ES7 290-2CA00-0XA0		
3	Ground terminals (10 pieces)	6ES5 728-8MA11				6	Terminal block, 12-pin, 10 pieces	6ES7 290-2AA00-0XA0		
Total						<div style="display: flex; justify-content: space-between; align-items: center;"> <span>Total</span> <span>+</span> <span>=</span> </div> <div style="display: flex; justify-content: space-between; align-items: center; margin-top: 10px;"> <span>Total price</span> <span>=</span> </div>				







2

### Input assignment

All inputs of the CPU 212, CPU 214, CPU 215 and CPU 214 can be used as standard inputs.

When the integrated functions are in use, certain inputs are assigned and are no longer available for standard tasks or other integrated functions.

The following tables specify which inputs are assigned in each case and the functions they perform.

#### CPU 212

Input	0.0	0.1	0.2	0.3	0.4	0.5	0.6	0.7
<b>Interrupt processing (INT)</b>	<b>INT 0</b>							
Function of input	fF/sF	—	—	—	—	—	—	—
<b>High-speed counters (HSC)</b>	<b>HSC 0</b>							
Signals	Up/down	—	—	—	—	—	—	—

#### CPU 214/215/216

Input	0.0	0.1	0.2	0.3	0.4	0.5	0.6	0.7	1.0	1.1	1.2	1.3	1.4	1.5	
<b>Interrupt processing (INT)</b>	<b>INT 0/1</b>	<b>INT 2/3</b>	<b>INT 4/5</b>	<b>INT 6/7</b>											
Signals	sF/fF	sF/fF	sF/fF	sF/fF	—	—	—	—	—	—	—	—	—	—	
<b>High-speed counters (HSC)</b>	<b>HSC 0</b>							<b>HSC 1</b>			<b>HSC 2</b>				
Signals	Mode 0	Up/dn.	—	—	—	—	—	Up/dn.	—	—	—	Up/dn.	—	—	—
	Mode 1	—	—	—	—	—	—	Up/dn.	—	Reset	—	Up/dn.	—	Reset	—
	Mode 2	—	—	—	—	—	—	Up/dn.	—	Reset	Enab.	Up/dn.	—	Reset	Enab.
	Mode 3	—	—	—	—	—	—	Up/dn.	Direct.	—	—	Up/dn.	Direct.	—	—
	Mode 4	—	—	—	—	—	—	Up/dn.	Direct.	Reset	—	Up/dn.	Direct.	Reset	—
	Mode 5	—	—	—	—	—	—	Up/dn.	Direct.	Reset	Enab.	Up/dn.	Direct.	Reset	Enab.
	Mode 6	—	—	—	—	—	—	Up	Down	—	—	Up	Down	—	—
	Mode 7	—	—	—	—	—	—	Up	Down	Reset	—	Up	Down	Reset	—
	Mode 8	—	—	—	—	—	—	Up	Down	Reset	Enab.	Up	Down	Reset	Enab.
	Mode 9	—	—	—	—	—	—	A	B	—	—	A	B	—	—
	Mode 10	—	—	—	—	—	—	A	B	Reset	—	A	B	Reset	—
	Mode 11	—	—	—	—	—	—	A	B	Reset	Enab.	A	B	Reset	Enab.

Legend:

INT: Interrupt  
HSC: High-speed counter  
—: Input not assigned  
fF: Detection of falling signal edge  
sF: Detection of rising signal edge  
Up: Pulse input for incremental counting  
Down: Pulse input for decremental counting

Enab.: Count enable input  
Reset: Reset input (hardware reset)  
Direct.: Counting direction input  
A: Signal 1 for 90° phase-shifted counter  
B: Signal 2 for 90° phase-shifted counter

## Dimensional diagrams

### Minimum clearance for installation

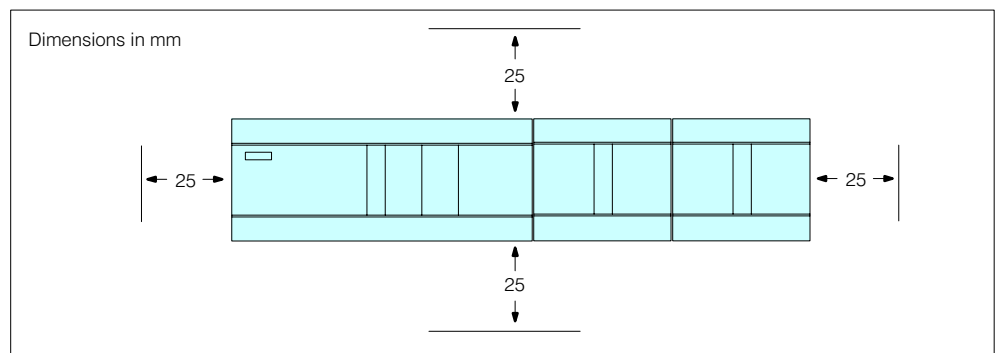

# SIMATIC S7-200 Configuring

## Dimensional diagrams (continued)

### CPU 221

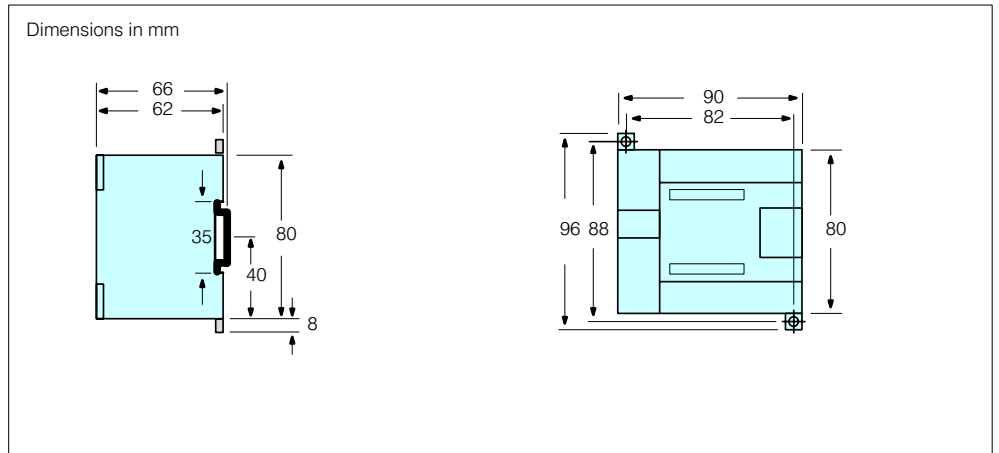

### CPU 212

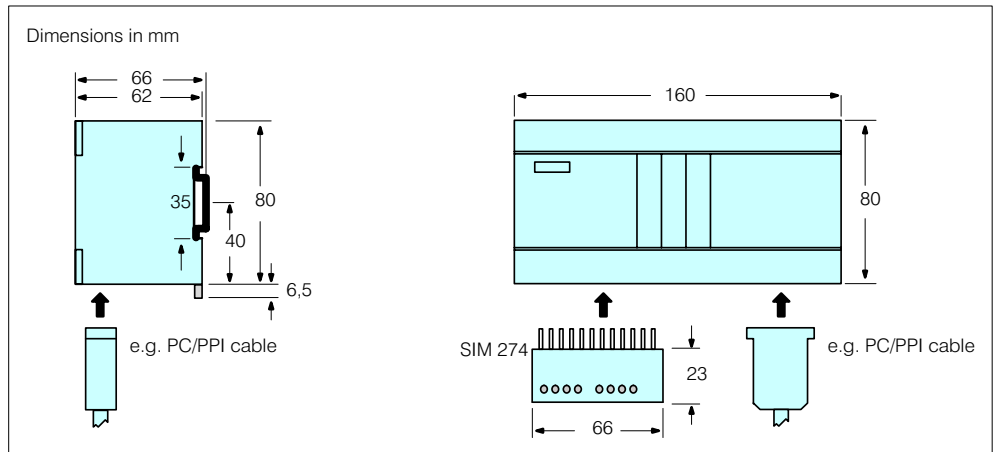

### CPU 222

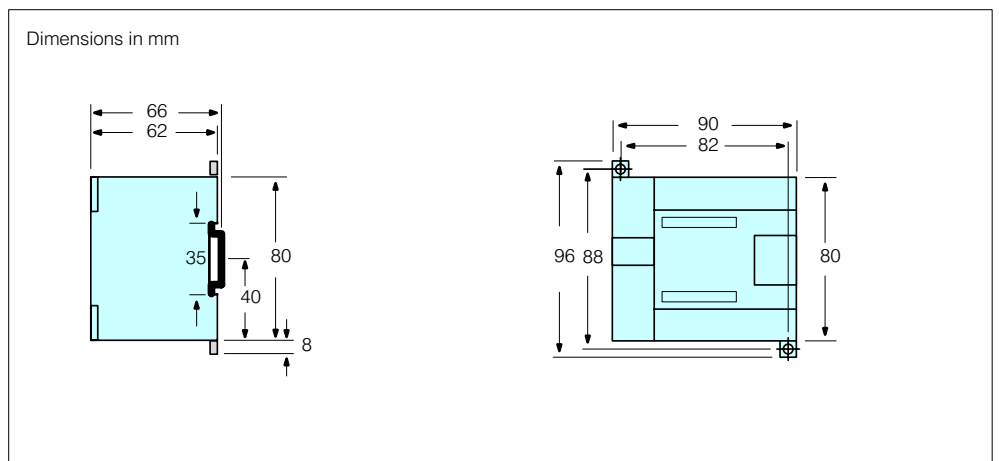

### CPU 214

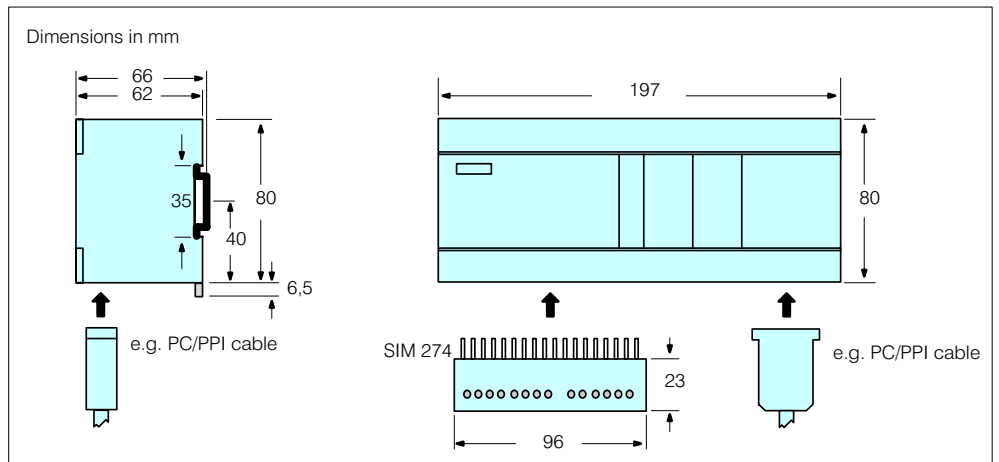

### CPU 224

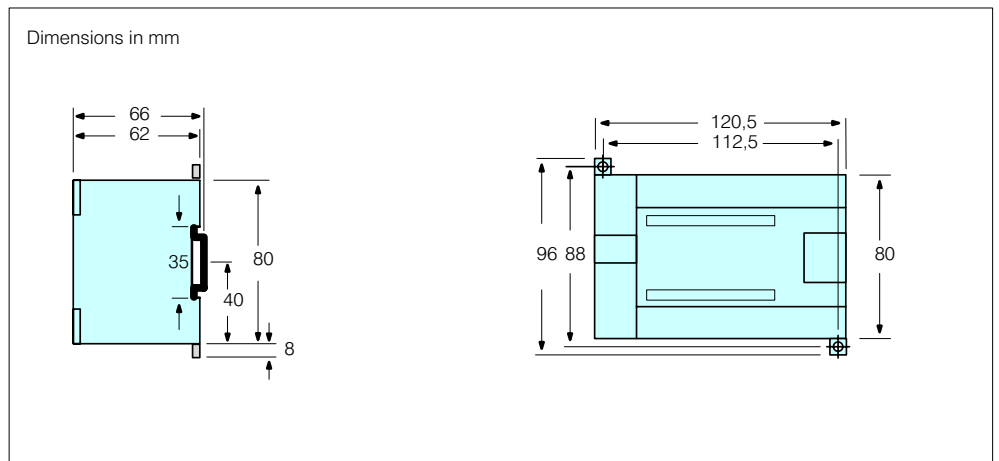

### CPU 215

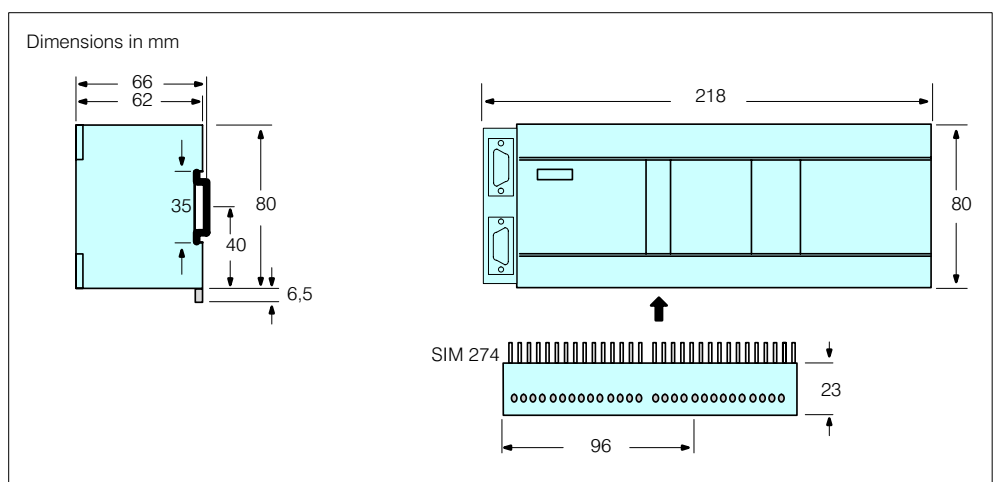

# SIMATIC S7-200 Configuring

## Dimensional diagrams (continued)

### CPU 216

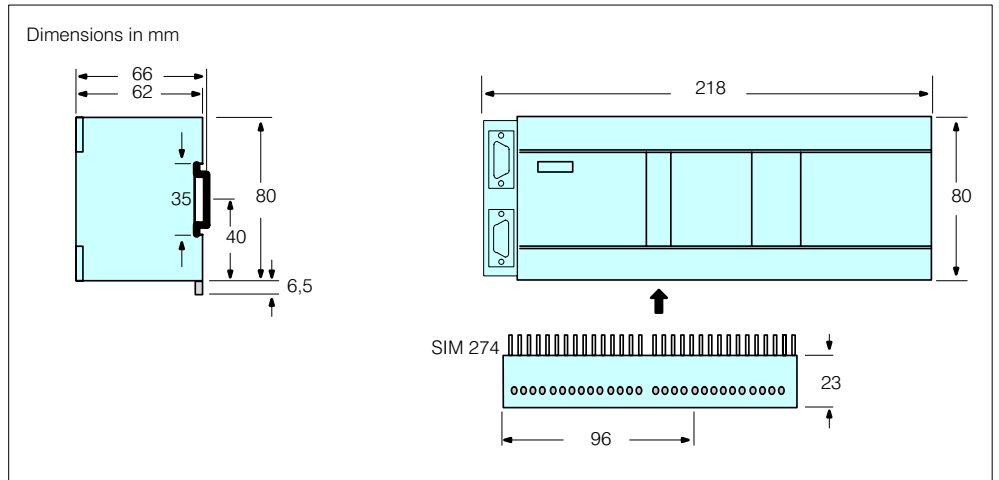

### EMs from the S7-21x series

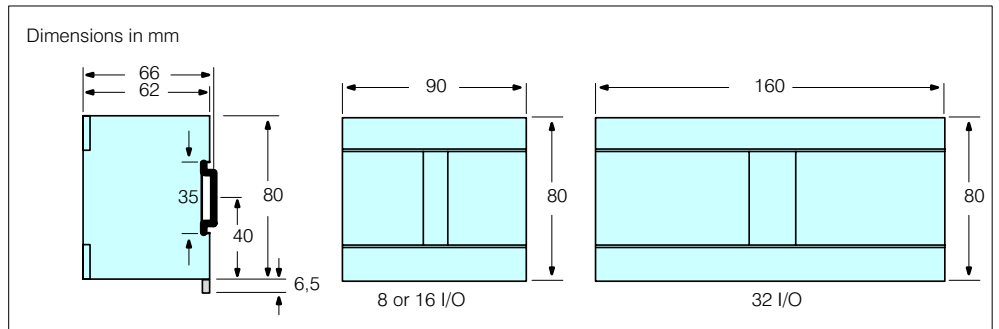

### EMs from the S7-22x series

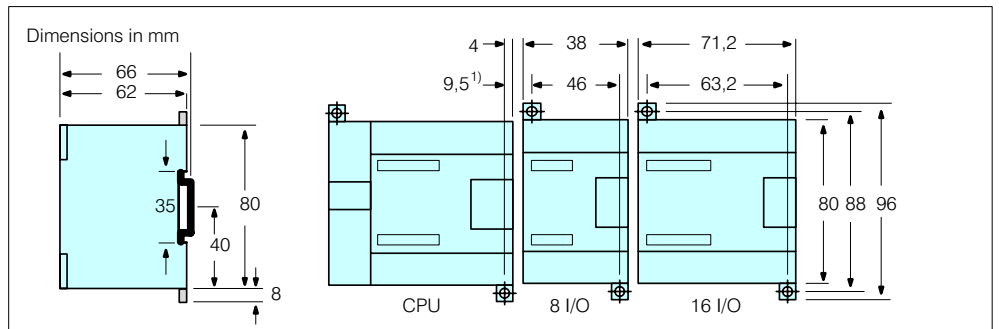

1) Minimum distance between the modules when mounting in switch gear cabinet with M4 type screws

### PC/PPI cable

